

Eight Output Switch with Serial Peripheral Interface I/O

The 33298 device is an eight output, low side power switch with 8-bit serial input control. The 33298 is a versatile circuit designed for automotive applications, but is well suited for other environments. The 33298 incorporates SMARTMOS™ technology, with CMOS logic, bipolar/MOS analog circuitry, and DMOS power MOSFETs. The 33298 interfaces directly with a microcontroller to control various inductive or incandescent loads.

The circuit's innovative monitoring and protection features include: Very Low Standby Current, SPI Cascade Fault Reporting Capability, Internal 53 V Clamp on Each Output, Output Specific Diagnostics, Independent Shutdown of Outputs.

The device is parametrically specified over an ambient temperature range of $-40^{\circ}\text{C} \leq T_A \leq 125^{\circ}\text{C}$ and $9.0\text{ V} \leq V_{\text{PWR}} \leq 16\text{ V}$ supply.

Features:

- Designed to Operate Over Wide Supply Voltages of 5.5 to 26.5 V
- Interfaces to Microprocessor Using 8-Bit SPI I/O Protocol up to 3.0 MHz
- 1.0 A Peak Current Outputs with Maximum $R_{\text{DS(on)}}$ of $1.6\ \Omega$ at $T_J - 150^{\circ}\text{C}$
- Outputs Current Limited to Accommodate In-rush Currents Associated with Switching Incandescent Loads
- Output Voltages Clamped to 53 V During Inductive Switching
- Maximum Sleep Current (I_{PWR}) of $25\ \mu\text{A}$
- Maximum of $4.0\ \text{mA}$ I_{DD} During Operation

33298

EIGHT OUTPUT SWITCH (SPI I/O)

Package Options

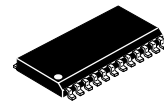

DW SUFFIX
PLASTIC PACKAGE
CASE 751E
SOICW (16+4+4)

ORDERING INFORMATION

Device	Temperature Range T_A	Package
MC33298DW	-40°C to 125°C	SOIC-24
MC33298DWR2	-40°C to 125°C	SOIC-24

33298 Simplified Application Diagram

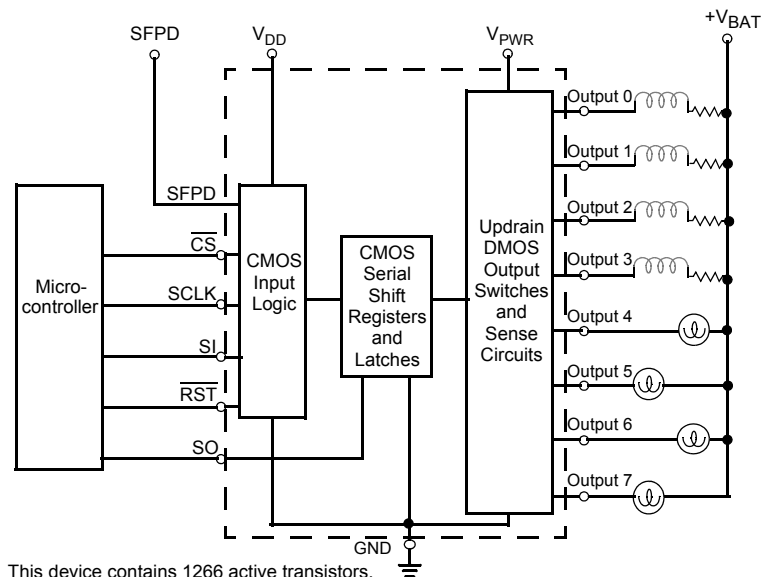

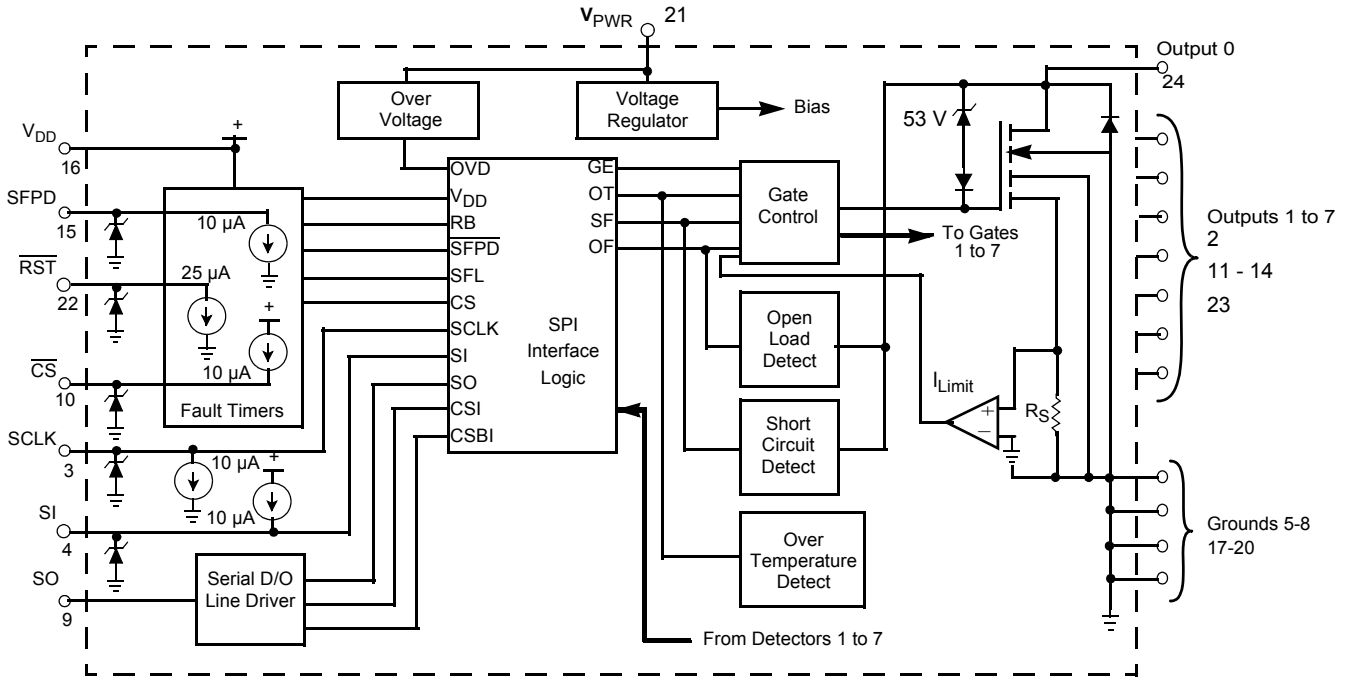

Figure 1. 33298 Simplified Block Diagram

FAULT OPERATION

Serial Output (SO) Pin Reports

Over Voltage	Over voltage condition reported
Over Temperature	Fault reported by Serial Output (SO) pin
Over Current	SO pin reports short to battery/supply or over current condition
Output ON, Open Load Fault	Not reported
Output OFF, Open Load Fault	SO pin reports output OFF open load condition

Device Shutdowns

Over Voltage	Total device shutdown at $V_{PWR} = 28$ to 36 V. All outputs are latched off while the SPI register is reset (cleared). Outputs can be turned back on with a new SPI command after V_{PWR} has decayed below 26.5 V.
Over Temperature	Only the output experiencing an over temperature condition turns off.
Over Current	Only the output experiencing an over current shuts down at 1.0 to 3.0 A after a 70 to 250 μ s delay, with SFPD pin grounded. All other outputs will continue to operate in a current limit mode, with no shutdown, if the SFPD pin is at 5.0 V (so long as the individual outputs are not experiencing thermal limit conditions).

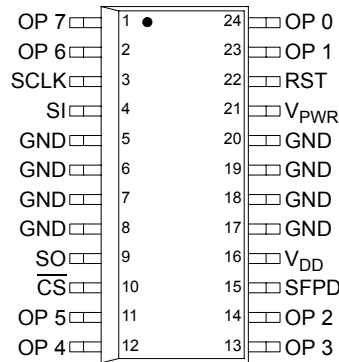

PIN FUNCTION DESCRIPTION

Pin	Pin Name	Description
1	OP7	Output 7. This pin provides connection to drain of output MOSFET number seven.
2	OP6	Output 6. This pin provides connection to drain of output MOSFET number six.
3	SCLK	System Clock. This pin clocks the internal Shift registers of the 33298.
4	SI	Serial Input. This pin is for the input of serial instruction data. SI information is read on the falling edge of SCLK.
5	GND	Ground. This pin provides connection to IC Power Ground and functions as part of heat sinking path.
6	GND	Ground. This pin provides connection to IC Power Ground and functions as part of heat sinking path.
7	GND	Ground. This pin provides connection to IC Power Ground and functions as part of heat sinking path.
8	GND	Ground. This pin provides connection to IC Power Ground and functions as part of heat sinking path.
9	SO	Serial Output. This pin is the <i>tri-stateable</i> output from the Shift register.
10	\overline{CS}	Chip Select. Whenever this pin is in a logic low state, data can be transferred from the MCU to the 33298 through the SI pin and from the 33298 to the MCU through the SO pin.
11	OP5	Output 5. This pin provides connection to drain of output MOSFET number five.
12	OP4	Output 4. This pin provides connection to drain of output MOSFET number four.
13	OP3	Output 3. This pin provides connection to drain of output MOSFET number three.
14	OP2	Output 2. This pin provides connection to drain of output MOSFET number two.
15	SFPD	Short Fault Protect Disable. This pin is used to prevent the outputs from latching-OFF because of an over current condition.
16	V _{DD}	Logic Supply.
17	GND	Ground. This pin provides connection to IC Power Ground and functions as part of heat sinking path.
18	GND	Ground. This pin provides connection to IC Power Ground and functions as part of heat sinking path.
19	GND	Ground. This pin provides connection to IC Power Ground and functions as part of heat sinking path.
20	GND	Ground. This pin provides connection to IC Power Ground and functions as part of heat sinking path.
21	V _{PWR}	Output MOSFET Gate Drive Supply.
22	\overline{RST}	RESET. This pin is active low. It is used to clear the SPI Shift register, thereby setting all output switches OFF.
23	OP1	Output 1. This pin provides connection to drain of output MOSFET number one.
24	OP0	Output 0. This pin provides connection to drain of output MOSFET number zero.

MAXIMUM RATINGS All voltages are with respect to ground unless otherwise noted.

Rating	Symbol	Value	Unit
Power Supply Voltage Normal Operation (Steady-State) Transient Conditions (Note 1)	$V_{PWR(SS)}$ $V_{PWR(PK)}$	- 1.5 to 26.5 - 13 to 60	V
Logic Supply Voltage (Note 2)	V_{DD}	- 0.3 to 7.0	V
Input Pin Voltage (Note 3)	V_{IN}	- 0.3 to 7.0	V
Output Clamp Voltage (Note 4) $2.0 \text{ mA} \leq I_{OUT} \leq 0.5 \text{ A}$	$V_{OUT(OFF)}$	50 to 75	V
Output Self-Limit Current	$I_{OUT(LIM)}$	3.0 to 6.0	A
Continuous Per Output Current (Note 5)	$I_{OUT(CONT)}$	1.0	A
ESD Voltage (Note 6) Human Body Model (Note 7) Machine Model (Note 8)	V_{ESD1} V_{ESD2}	2000 200	V
Output Clamp Energy (Note 9) Repetitive: $T_J = 25^\circ\text{C}$ $T_J = 124^\circ\text{C}$ Non-Repetitive: $T_J = 25^\circ\text{C}$ $T_J = 124^\circ\text{C}$	E_{CLAMP}	100 30 2.0 0.5	mJ mJ J J
Recommended Frequency of SPI Operation (Note 11)	f_{SPI}	2.0	MHz
Storage Temperature	T_{STG}	- 55 to 150	$^\circ\text{C}$
Operating Case Temperature	T_C	- 40 to 125	$^\circ\text{C}$
Operating Junction Temperature	T_J	- 40 to 150	$^\circ\text{C}$
Power Dissipation ($T_A = 25^\circ\text{C}$) (Note 12)	P_D	3.0	W
Soldering Temperature (Note 13)	T_{SOLDER}	260	$^\circ\text{C}$

Notes:

1. Transient capability with external 100 Ω resistor in series with VP pin and supply.
2. Exceeding these limits may cause a malfunction or permanent damage to the device.
3. Exceeding the limits on SCLK, SI, $\overline{\text{CS}}$, SFPD, or $\overline{\text{RST}}$ pins may cause permanent damage to the device.
4. With output OFF.
5. Continuous output current rating so long as maximum junction temperature is not exceeded. Operation at 125 $^\circ\text{C}$ ambient temperature will require maximum output current computation using package $R_{\theta JA}$.
6. ESD data available upon request.
7. ESD1 testing is performed in accordance with the Human Body Model ($C_{Zap} = 200 \text{ pF}$, $R_{Zap} = 1500 \Omega$).
8. ESD2 testing is performed in accordance with the Machine Model ($C_{Zap} = 200 \text{ pF}$, $R_{Zap} = 0 \Omega$).
9. Maximum output clamp energy capability at 150 $^\circ\text{C}$ junction temperature using a single non-repetitive pulse method.
10. Guaranteed and production tested for 2.0 MHz SPI operation, but demonstrated to operate to 8.5 MHz at 25 $^\circ\text{C}$.
11. See Figure 20 for Thermal model.
12. Soldering temperature limit is for 10 seconds maximum duration; not designed for immersion soldering; exceeding these limits may cause malfunction or permanent damage to the device. Contact Motorola Sales Office for device immersion soldering time/temperature limits.

MAXIMUM RATINGS All voltages are with respect to ground unless otherwise noted.

Rating	Symbol	Value	Unit
Thermal Resistance (Junction-to-Ambient)	$R_{\theta JA}$		°C/W
Case 738 Package			
All Outputs ON (Note 14)		31	
Single Output ON (Note 14)		37	
Case 751E Package			
All Outputs ON (Note 13)		34	
Single Output ON (Note 14)	40		

Notes:

- 13. Thermal resistance from Junction-to-Ambient with all outputs ON and dissipating equal power.
- 14. Thermal resistance from Junction -to-Ambient with a single output ON.

STATIC ELECTRICAL CHARACTERISTICS

Characteristics noted under conditions $4.5\text{ V} \leq V_{DD} \leq 5.5\text{ V}$, $9.0\text{ V} \leq V_{PWR} \leq 16\text{ V}$, $-40^\circ\text{C} \leq T_A \leq 125^\circ\text{C}$, unless otherwise noted. Typical values noted reflect the approximate value with $V_{Bat} = 13\text{ V}$, $T_A = 25^\circ\text{C}$.

Characteristic	Symbol	Min	Typ	Max	Unit
Power Input					
Supply Voltage Range					V
Quasi-Functional (Note 15)	$V_{PWR(QF)}$	5.5	—	9.0	
Fully Operational	$V_{PWR(FO)}$	9.0	—	26.5	
Supply Current (All Outputs ON, $I_{OUT} = 0.5\text{ A}$) (Note 16)	$V_{PWR(ON)}$	—	1.0	2.0	V
Sleep State Supply Current ($V_{DD} = 0.5\text{ V}$)	$I_{PWR(SS)}$	—	1.0	50	μA
Sleep State Output Leakage Current (per Output, $V_{DD} = 0.5\text{ V}$)	$I_{OUT(SS)}$	—	—	50	μA
Over Voltage Shutdown	V_{OV}	28	—	36	V
Over Voltage Shutdown Hysteresis	$V_{OV(HYS)}$	0.2	—	1.5	V
Logic Supply Voltage	V_{DD}	4.5	—	5.5	V
Logic Supply Current (with any combination of Outputs ON)	I_{DD}	—	—	4.0	mA
Logic Supply Under Voltage Lockout Threshold (Note 17)	$V_{DD(UVLO)}$	2.0	—	4.5	V

Notes:

15. SPI inputs and outputs operational; Fault status reporting may not be fully operational within this voltage range.
16. Value reflects normal operation (no faults) with all outputs ON. Each ON output contributes approximately 20 μA to I_{PWR} . Each output experiencing a *soft short* condition contributes approximately 0.5 mA to I_{PWR} . A *soft short* is defined as any load current causing the output source current to self-limit. A *hard* output short is a very low impedance short to supply.
17. For V_{DD} less than the Under Voltage Lockout Threshold voltage, all data registers are reset and all outputs are disabled.

STATIC ELECTRICAL CHARACTERISTICS (continued)

Characteristics noted under conditions $4.5\text{ V} \leq V_{DD} \leq 5.5\text{ V}$, $9.0\text{ V} \leq V_{PWR} \leq 16\text{ V}$, $-40^\circ\text{C} \leq T_A \leq 125^\circ\text{C}$, unless otherwise noted. Typical values noted reflect the approximate value with $V_{PWR} = 13\text{ V}$, $T_A = 25^\circ\text{C}$.

Characteristic	Symbol	Min	Typ	Max	Unit
Power Output					
Drain-to-Source ON Resistance ($I_{OUT} = 0.5\text{ A}$, $T_J = 25^\circ\text{C}$) $V_{PWR} = 5.5\text{ V}$ $V_{PWR} = 9.0\text{ V}$ $V_{PWR} = 13\text{ V}$	$R_{DS(ON)}$	— — —	— 0.4 0.35	10 0.5 0.45	Ω
Drain-to-Source ON Resistance ($I_{OUT} = 0.5\text{ A}$, $T_J = 150^\circ\text{C}$) $V_{PWR} = 5.5\text{ V}$ $V_{PWR} = 9.0\text{ V}$ $V_{PWR} = 13\text{ V}$	$R_{DS(ON)}$	— — —	— 7.5 0.65	1.8 0.9 0.8	Ω
Output Self-Limiting Current Outputs Programmed ON, $V_{OUT} = 0.6 V_{DD}$	$I_{OUT(LIM)}$	3.0	4.0	6.0	A
Output Fault Detect Threshold (Note 18) Output Programmed OFF	$V_{OUTth(F)}$	0.6	0.7	0.8	V_{DD}
Output OFF Open Load Detect Current (Note 19) Output Programmed OFF, $V_{OUT} = 0.6 V_{DD}$	I_{OCO}	30	50	100	μA
Output Clamp Voltage $2.0\text{ mA} \leq I_{OUT} \leq 200\text{ mA}$	V_{OK}	50	60	75	V
Output Leakage Current ($V_{DD} \leq 2.0\text{ V}$) (Note 20)	$I_{OUT(LKG)}$	-50	0	50	μA
Over Temperature Shutdown (Outputs OFF) (Note 21)	T_{LIM}	155	170	185	$^\circ\text{C}$
Over Temperature Shutdown Hysteresis (Note 21)	$T_{LIM(HYS)}$	—	10	20	$^\circ\text{C}$

Notes:

18. Output Fault Detect Threshold with outputs programmed OFF. Output fault detect thresholds are the same for output opens and shorts.
19. Output OFF Open Load Detect Current is the current required to flow through the load for the purpose of detecting the existence of an open load condition when the specific output is commanded to be OFF.
20. Output leakage current measured with the output OFF and at 16 V.
21. This parameter is guaranteed by design, but it is not production tested.

STATIC ELECTRICAL CHARACTERISTICS (continued)

Characteristics noted under conditions $4.5\text{ V} \leq V_{DD} \leq 5.5\text{ V}$, $9.0\text{ V} \leq V_{PWR} \leq 16\text{ V}$, $-40^\circ\text{C} \leq T_A \leq 125^\circ\text{C}$, unless otherwise noted. Typical values noted reflect the approximate value with $V_{PWR} = 13\text{ V}$, $T_A = 25^\circ\text{C}$.

Characteristic	Symbol	Min	Typ	Max	Unit
Digital Interface					
Input Logic High Voltage (Note 22)	V_{IH}	0.7	—	1.0	V_{DD}
Input Logic Low Voltage (Note 23)	V_{IL}	0	—	0.2	V_{DD}
Input Logic Voltage Hysteresis (Note 24)	$V_{I(HYS)}$	50	100	500	mV
Input Logic Current (Note 25)	I_{IN}	-10	0	10	μA
$\overline{\text{RST}}$ Pull-Up Current ($\overline{\text{RST}} = 0.7 V_{DD}$)	$I_{\overline{\text{RST}}}$	10	22	50	μA
SFPD Pull-Down Current (SFPD = $0.2 V_{DD}$)	I_{SFPD}	10	22	50	μA
SO High State Output Voltage ($I_{OH} = 1.0\text{ mA}$)	V_{SOH}	$V_{DD} - 1.0\text{ V}$	$V_{DD} - 0.6\text{ V}$	—	V
SO Low State Output Voltage ($I_{OL} = -1.6\text{ mA}$)	V_{SOL}	—	0.2	0.4	V
SO Tri-State Leakage Current ($\overline{\text{CS}} = 0.7 V_{DD}$, $0\text{ V} \leq V_{SO} \leq V_{DD}$)	I_{SOT}	-10	0	10	μA
Input Capacitance ($0\text{ V} \leq V_{DD} \leq 5.5\text{ V}$) (Note 26)	C_{IN}	—	—	12	pF
SO Tri-State Capacitance ($0\text{ V} \leq V_{DD} \leq 5.5\text{ V}$) (Note 27)	C_{SOT}	—	—	20	pF

Notes:

22. Upper and lower logic threshold voltage levels apply to SI, $\overline{\text{CS}}$, SCLK, $\overline{\text{RST}}$, and SFPD inputs.
23. Lower logic threshold voltage range applies to SI, $\overline{\text{CS}}$, SCLK, Reset, and SFPD input signals.
24. Only the SFPD and Reset inputs have hysteresis. This parameter is guaranteed by design, but it is not production tested.
25. Input current of SCLK, SI and $\overline{\text{CS}}$ logic control inputs.
26. Input capacitance of SI, $\overline{\text{CS}}$, SCLK, $\overline{\text{RST}}$, and SFPD for $0\text{ V} \leq V_{DD} \leq 5.5\text{ V}$. This parameter is guaranteed by design, but it is not production tested.
27. Tri-state capacitance of SO for $0\text{ V} \leq V_{DD} \leq 5.5\text{ V}$. This parameter is guaranteed by design, but it is not production tested.

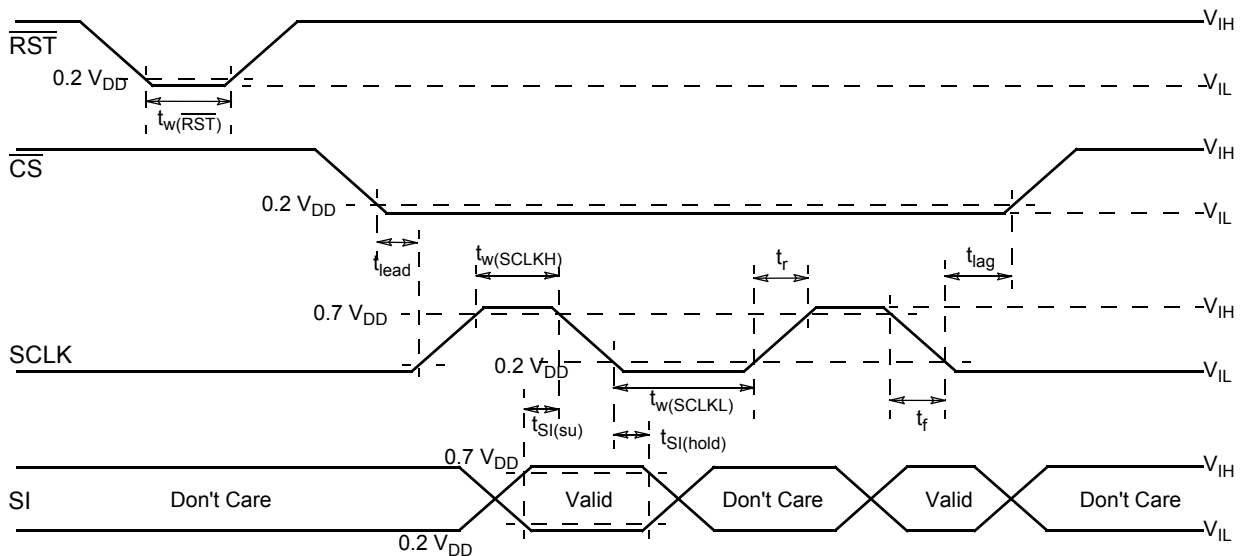

Figure 2. Input Timing Switch Characteristics

DYNAMIC ELECTRICAL CHARACTERISTICS

Characteristics noted under conditions $4.5\text{ V} \leq V_{DD} \leq 5.5\text{ V}$, $9.0\text{ V} \leq V_{PWR} \leq 16\text{ V}$, $-40^\circ\text{C} \leq T_A \leq 125^\circ\text{C}$, unless otherwise noted. Typical values noted reflect the approximate parameter mean at $T_A = 25^\circ\text{C}$ under nominal conditions, unless otherwise noted.

Characteristic	Symbol	Min	Typ	Max	Unit
Power Output Timing					
Output Rise Time ($V_{PWR} = 13\text{ V}$, $R_L = 26\ \Omega$) (Note 28)	t_R	0.4	1.5	20	μs
Output Fall Time ($V_{PWR} = 13\text{ V}$, $R_L = 26\ \Omega$) (Note 28)	t_F	0.4	2.5	20	μs
Output Turn ON Delay Time ($V_{PWR} = 13\text{ V}$, $R_L = 26\ \Omega$) (Note 29)	$t_{DLY(ON)}$	1.0	5.0	15	μs
Output Turn-OFF Delay Time ($V_{PWR} = 13\text{ V}$, $R_L = 26\ \Omega$) (Note 30)	$t_{DLY(OFF)}$	1.0	5.0	15	μs
Output Short Fault Disable Report Delay (Note 31) SFPD = $0.2 \times V_{DD}$	$t_{DLY(SF)}$	25	50	100	μs
Output OFF Fault Report Delay (Note 32) SFPD = $0.2 \times V_{DD}$	$t_{DLY(OFF)}$	25	50	100	μs

Notes:

28. Output Rise and Fall time respectively measured across a $26\ \Omega$ resistive load at 10 to 90 percent, and 90 to 10 percent voltage points.
29. Output Turn ON Delay time measured from 50 percent rising edge of \overline{CS} to 90 percent of Output OFF voltage (V_{PWR}) with $R_L = 26\ \Omega$ resistive load.
30. Output Turn OFF Delay time measured from 50 percent rising edge of \overline{CS} to 10 percent of Output OFF voltage (V_{PWR}) with $R_L = 26\ \Omega$ resistive load.
31. Output Short Fault Delay time measured from rising edge of CS to $I_{OUT} = 2.0\text{ A}$ point with output ON, $V_{OUT} = 5.0\text{ V}$, and SFPD = $0.2 \times V_{DD}$. See Figures 8 and 10.
32. Output OFF Fault Report Delay measured from 50 percent rising edge of \overline{CS} to rising edge of output. See Figure 9.

DYNAMIC ELECTRICAL CHARACTERISTICS

Characteristics noted under conditions $4.5\text{ V} \leq V_{DD} \leq 5.5\text{ V}$, $9.0\text{ V} \leq V_{PWR} \leq 16\text{ V}$, $-40^\circ\text{C} \leq T_A \leq 125^\circ\text{C}$, unless otherwise noted. Typical values noted reflect the approximate parameter mean at $T_A = 25^\circ\text{C}$ under nominal conditions, unless otherwise noted.

Characteristic	Symbol	Min	Typ	Max	Unit
Digital Interface Timing					
SCLK Clock Period (Note 33)	t_{pSCLK}	500	—	—	ns
SCLK Clock High Time	t_{wSCLKH}	175	—	—	ns
SCLK Clock Low Time	t_{wSCLKL}	175	—	—	ns
Required Low State Duration for Reset ($V_{IL} < 0.2 V_{DD}$) (Note 34)	$t_{w(\overline{RST})}$	250	50	—	ns
Falling Edge of \overline{CS} to Rising Edge of SCLK (Required Setup Time)	t_{LEAD}	250	50	—	ns
Falling Edge of SCLK to Rising Edge of \overline{CS} (Required for Setup Time)	t_{LAG}	250	50	—	ns
SI to Falling Edge of SCLK (Required for Setup Time)	t_{SISU}	125	25	—	ns
Falling Edge of SCLK to SI (Required for Hold Time)	$t_{SI(HOLD)}$	125	25	—	ns
SO Rise Time ($C_L = 200\text{ pF}$)	t_{rSO}	—	25	75	ns
SO Fall Time ($C_L = 200\text{ pF}$)	t_{fSO}	—	25	75	ns
SI, \overline{CS} , SCLK, Incoming Signal Rise Time (Note 35)	t_{rSI}	—	—	200	ns
SI, \overline{CS} , SCLK, Incoming Signal Fall Time (Note 35)	t_{fSI}	—	—	200	ns
Time from Falling Edge of \overline{CS} to SO Low Impedance (Note 36)	$t_{SO(EN)}$	—	—	200	ns
Time from Rising Edge of \overline{CS} to SO High Impedance (Note 37)	$t_{SO(DIS)}$	—	—	200	ns
Time from Rising Edge of SCLK to SO Data Valid (Note 38) $0.2 V_{DD} \leq SO \leq 0.8 V_{DD}$, $C_L = 200\text{ pF}$	t_{VALID}	—	50	125	ns

Notes:

33. Clock period include 75 ns rise plus 75 ns fall transition in addition to clock high and low time.
34. \overline{RST} Low duration measured with outputs enabled and going to OFF or disabled condition.
35. Rise and Fall time of incoming SI, \overline{CS} , and SCLK signals suggested for design consideration to prevent the occurrence of double pulsing.
36. Time required for output status data to be available for use at the SO pin.
37. Time required for output status data to be terminated at the SO pin.
38. Time required to obtain valid data out from SO following the rise of SCLK. See Figure 5.

Electrical Performance Curves

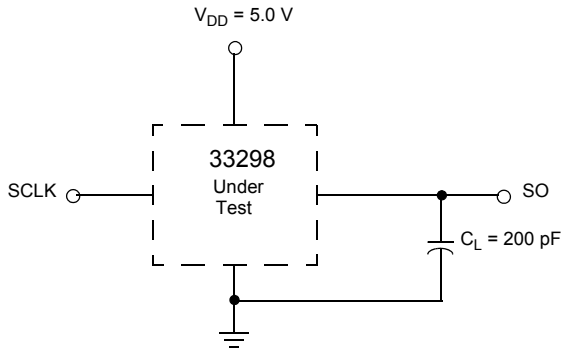

C_L represents the total capacitance of the test fixture and probe.

Figure 3. Valid Data Delay Time and Valid Time Test Circuit

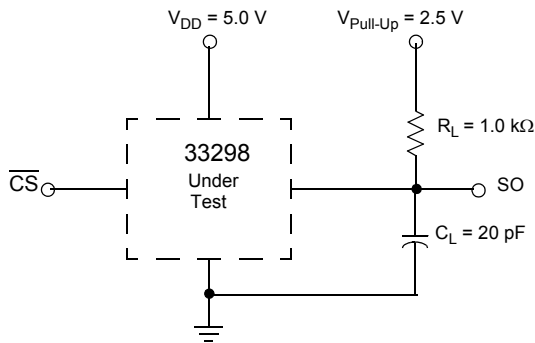

C_L represents the total capacitance of the test fixture and probe.

Figure 4. Enable and Disable Time Test Circuit

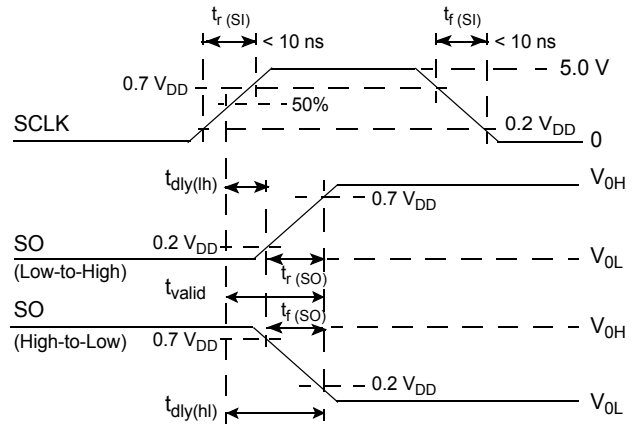

SO (Low-to-High) is for an output with internal conditions such that the low-to-high transition of \overline{CS} causes the SO output to switch from high to low.

Figure 5. Valid Data Delay Time and Valid Time Waveforms

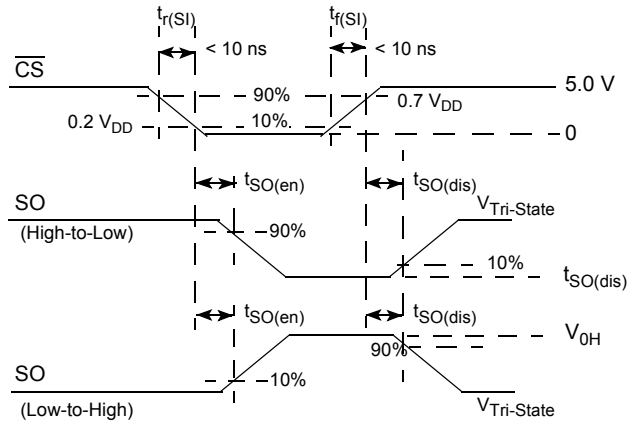

1. SO (high-to-low) waveform is for SO output with internal conditions such that SO output is low except when an output is disabled as a result of detecting a circuit fault with CS in a High Logic state, e.g. open load.
2. SO (low-to-high) waveform is for SO output with internal conditions such that SO output is high except when an output is disabled as a result of detecting a circuit fault with CS in a High Logic state, e.g. shorted load.

Figure 6. Enable and Disable Time Waveforms

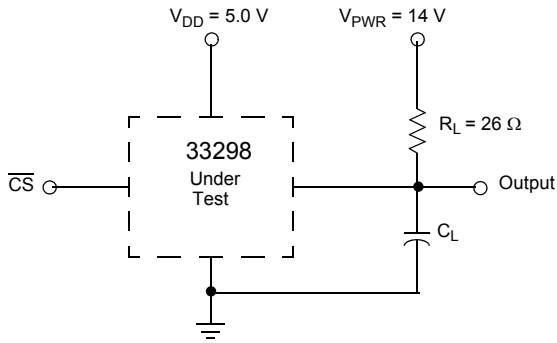

C_L represents the total capacitance of the test fixture and probe.

Figure 7. Switching Time Test Circuit

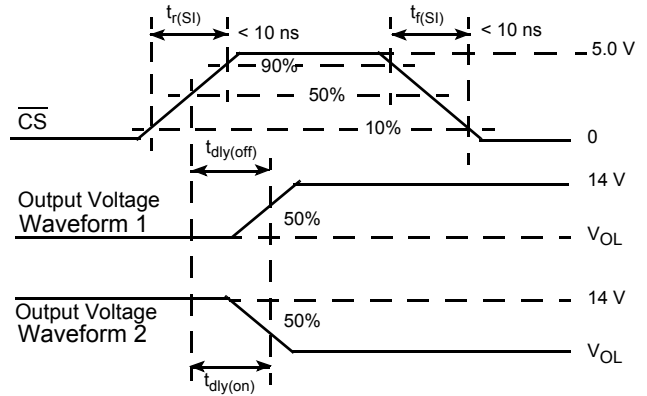

1. $t_{dly(on)}$ and $t_{dly(off)}$ are turn-on and turn-off propagation delay times.
2. Turn-off is an output programmed from an ON to an OFF state.
3. Turn-on is an output programmed from an OFF to an ON state.

Figure 9. Turn-On/Off Waveforms

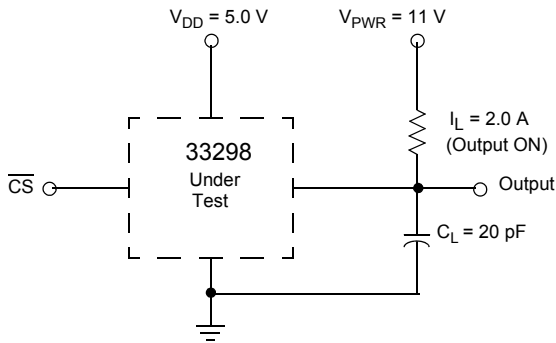

C_L represents the total capacitance of the test fixture and probe.

Figure 8. Output Fault Unlatch Disable Delay Test Circuit

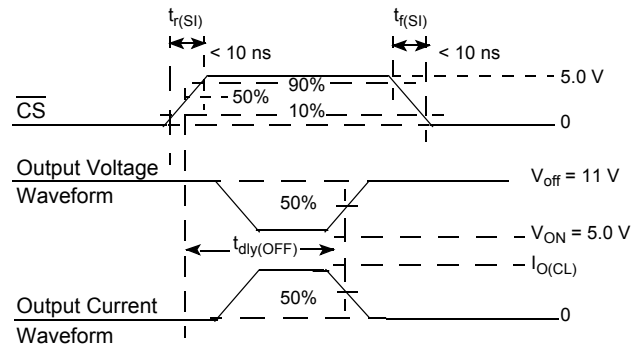

1. $t_{pdly(off)}$ is the output fault unlatch disable propagation delay time required to correctly report an output fault after \overline{CS} rises. It represents an output commanded ON while having an existing output short (over current) to supply.
2. The SFPD pin ≤ 0.2 V

Figure 10. Output Fault Unlatch Disable Delay Waveforms

SYSTEM/APPLICATION INFORMATION

INTRODUCTION

The 33298 was conceived, specified, designed, and developed for automotive applications. It is an eight output low side power switch having 8-bit serial control. The 33298 incorporates SMARTMOS™ technology having effective 1.5 μ CMOS logic, bipolar/MOS analog circuitry, and independent state of the art double diffused MOS (DMOS) power output transistors. Many benefits are realized as a direct result of using this mixed technology. A simplified block diagram delineates 33298 in Figure 1.

Where bipolar devices require considerable control current for their operation, structured MOS devices, since they are voltage controlled, require only transient gate charging current affording a significant decrease in power consumption. The CMOS capability of the SMARTMOS™ process allows significant amounts of logic to be economically incorporated into the monolithic design. Additionally, the bipolar/MOS analog circuits embedded within the updrain power DMOS output transistors monitor and provide fast, independent protection control functions for each individual output. All outputs have internal 45 V at 0.5 A independent output voltage clamps to provide fast inductive turn-off and transient protection.

The 33298 uses high efficiency updrain power DMOS output transistors exhibiting very low room temperature drain-to-source ON resistance values ($R_{DS(on)} \leq 1.0 \Omega$ at 13 V V_{PWR}) and dense CMOS control logic. Operational bias currents of less than 2.0 mA (1.0 mA typical) with any combination of outputs ON are the result of using this mixed technology and would not be possible with bipolar structures. To accomplish a comparable functional feature set using a bipolar structure approach would result in a device requiring hundreds of milliamperes of internal bias and control current. This would represent a very large amount of power to be consumed by the device itself and not available for load use.

During operation, the 33298 functions as an eight output serial switch serving as a microcontroller (MCU) bus expander and buffer with fault management and fault reporting features.

In doing so, the device directly relieves the MCU of the fault management functions.

The 33298 directly relieves the MCU of the fault management functions. The 33298 directly interfaces to an MCU, operating at system clock serial frequencies in excess of 3.0 MHz. It uses a Synchronous Peripheral Interface (SPI) for control and diagnostic readout. Figure 11 illustrates the basic SPI configuration between an MCU and one 33298.

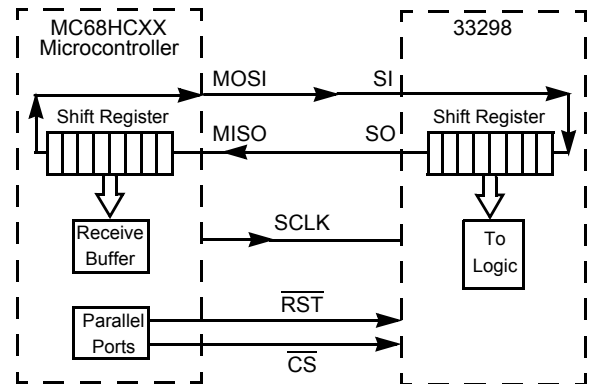

Figure 11. SPI Interface with Microcontroller

The circuit can also be used in a variety of other applications in the computer, telecommunications, and industrial fields. It is parametrically specified over an input *battery* /supply range of 9.0 to 16 V but is designed to operate over a considerably wider range of 5.5 to 26.5 V. The design incorporates the use of Logic Level MOSFETs as output devices. These MOSFETs are sufficiently turned ON with a gate voltage of less than 5.0 V thus eliminating the need for an internal charge pump. Each output is identically sized and *independent* in operation. The efficiency of each output transistor, at room temperature provides as little as 9.0 V supply (V_{PWR}), the maximum $R_{DS(on)}$ of an output

All inputs are compatible with 5.0 V CMOS logic levels, incorporating negative or inverted logic. Whenever an input is programmed to a logic low state (<1.0 V) the corresponding low side switched output being controlled will be active low and turned ON. Conversely, whenever an input is programmed to a logic high state (>3.0 V), the output being controlled will be high and turned OFF.

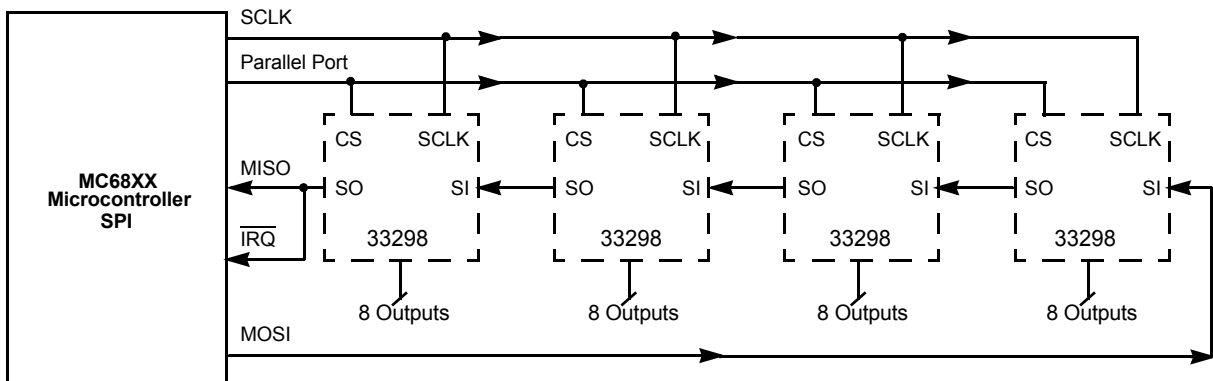

Figure 12. 33298 SPI System Daisy Chain

One main advantage of the 33298 is the serial port. When coupled to an MCU, it receives ON/OFF commands from the MCU and in return transmits the drain status of the device's output switches. Many devices can be *daisy-chained* together, forming a larger system, illustrated in Figure 12.

Note In this example, only one dedicated MCU parallel port (aside from the required SPI) is required for chip select to control 32 possible loads.

Multiple 33298 devices can also be controlled in a parallel input fashion using SPI, illustrated in Figure 13. This figure shows a possible 24 loads being controlled by only three dedicated parallel MCU ports used for chip select.

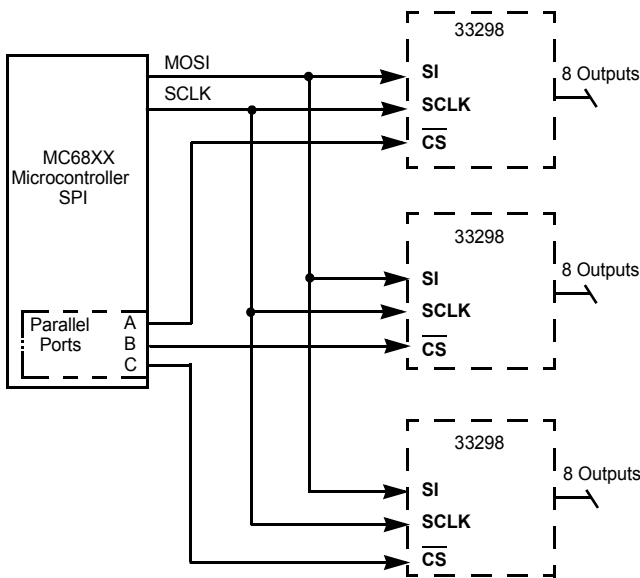

Figure 13. Parallel Input SPI Control

Figure 14 illustrates a basic method of controlling multiple 33298 devices using two MCUs. A system can have only one master MCU at any given instant of time and one or more slave MCUs. Master control of the system must pass from one MCU

to the other in an orderly manner. The master MCU supplies the system clock signal (top MCU designated the master); the lower MCU being the slave. It is possible to have a system with more than one master; however, not at the same time. Only when the master is not communicating can a slave assume the *mastership* and communicate. MCU master control is switched through the use of the slave select (\overline{SS}) pin of the MCUs. A master will become a slave when it detects a logic low state on its \overline{SS} pin.

These basic examples make the 33298 very attractive for applications where a large number of loads require efficient control. To this end, the popular Synchronous Serial Peripheral Interface (SPI) protocol is incorporated to communicate efficiently with the MCU.

SPI System Attributes

The SPI system is flexible enough to communicate directly with numerous standard peripherals and MCUs available from Motorola and other semiconductor manufacturers. SPI reduces the number of pins necessary for input/output (I/O) on the 33298. It also offers an easy means of expanding the I/O function using few MCU pins. The SPI system of communication consists of the MCU transmitting, in return it receives one data-bit of information per system clock cycle.

Data-bits of information are simultaneously transmitted by one pin, Microcontroller Out Serial In (MOSI), and received by another pin, Microcontroller In Serial Out (MISO), of the MCU.

Some features of SPI are:

- Full duplex, three-wire synchronous data transfer
- Each microcontroller can be a master or a slave
- Provides write collision flag protection
- Provides end of message interrupt flag
- Four I/Os associated with SPI (MOSI, MISO, SCLK, \overline{SS})

Drawbacks to SPI are:

- An MCU is required for efficient operational control
- In contrast to parallel input control it is slower at performing pulse width modulating (PWM) functions.

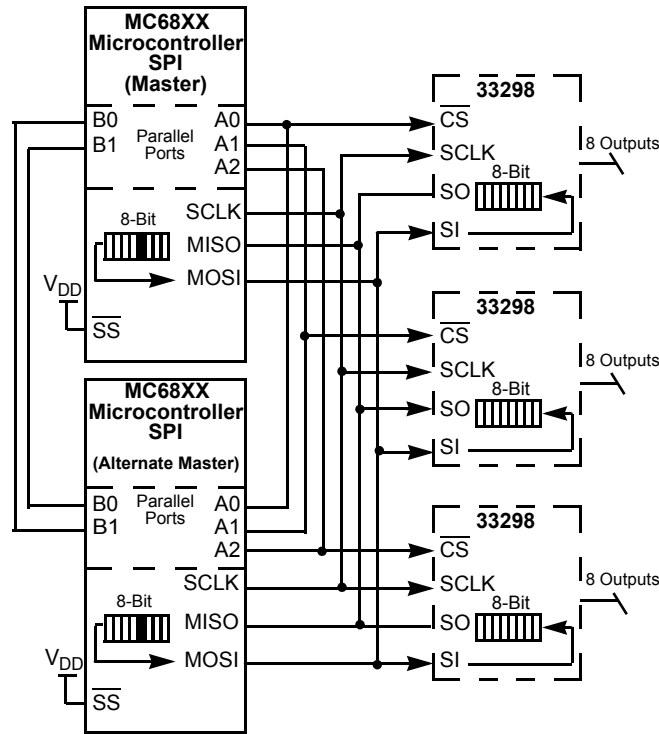

Figure 14. Multiple MCU SPI Control

FUNCTIONAL PIN DESCRIPTION

$\overline{\text{CS}}$ Pin

The 33298 receives its MCU communication through the $\overline{\text{CS}}$ pin. Whenever this pin is in a logic low state, data can be transferred from the MCU to the 33298 by way of the SI pin and from the 33298 to the MCU through the SO pin. Clocked-in data from the MCU is transferred from the 33298 Shift register and latched into the power outputs on the rising edge of the $\overline{\text{CS}}$ signal. On the falling edge of the $\overline{\text{CS}}$ signal, drain status information is transferred from the power outputs then loaded into the Shift register of the device. The $\overline{\text{CS}}$ pin also controls the output driver of the serial output (SO) pin. Whenever the $\overline{\text{CS}}$ pin goes to a logic low state, the SO pin output driver is enabled allowing information to be transferred from the 33298 to the MCU. To avoid data corruption or the generation of spurious data, it is essential the high-to-low transition of the $\overline{\text{CS}}$ signal occur only when SCLK is in a logic low state.

SCLK Pin

The system clock (SCLK) pin clocks the internal shift registers of the 33298. The serial input (SI) pin accepts data into the Input Shift register on the falling edge of the SCLK signal while the serial output (SO) pin shifts data information out of the SO line driver on the rising edge of the SCLK signal. False clocking of the Shift register must be avoided to guarantee validity of data. It is essential the SCLK pin be in a logic low state whenever the chip select bar ($\overline{\text{CS}}$) pin makes any

transition. For this reason, it is recommended, though not absolutely necessary, the SCLK pin be kept in a low logic state as long as the device is not accessed ($\overline{\text{CS}}$ in logic high state). When $\overline{\text{CS}}$ is in a logic high state, signals at the SCLK and SI pins are ignored and SO is tri-stated (high impedance). See the Data Transfer Timing diagram in Figure 16.

SI Pin

This pin is for the input of serial instruction (SI) data. SI is read on the falling edge of SCLK. A logic high state present on this pin when the SCLK signal rises will program a specific output OFF. In turn, the pin turns OFF the specific output on the rising edge of the $\overline{\text{CS}}$ signal. Conversely, a logic low state present on the SI pin will program the output ON, In turn, the pin turns ON the specific output on the rising edge of the $\overline{\text{CS}}$ signal.

To program the eight outputs of the 33298 ON or OFF, an 8-bit serial stream of data is required to be synchronously entered into the SI pin starting with Output 7, followed by Output 6, Output 5, and so on, to Output 0. Referring to Figure 15, the DO bit is the most significant bit (MSB) corresponding to Output 7. For each rise of the SCLK signal, with $\overline{\text{CS}}$ held in a logic low state, a data-bit instruction (ON or OFF) is synchronously loaded into the Shift register per the data-bit SI state. The Shift register is full after eight bits of information have been entered. To preserve data integrity, care should be taken to not transition SI as SCLK transitions from a low-to-high logic state.

SO Pin

The serial output (SO) pin is the *tri-stateable* output from the Shift register. The SO pin remains in a high impedance state until the CS pin goes to a logic low state. The SO data reports the drain status, either high or low relative to the previous command word. The SO pin changes state on the rising edge of SCLK and reads out on the falling edge of SCLK. When an output is OFF and not faulted, the corresponding SO data-bit is a high state. When an output is ON, and there is no fault, the corresponding data-bit on the SO pin will be a low logic state. The SI/SO shifting of data follows a first-in-first-out (FIFO) protocol with both input and output words transferring the MSB first. Referring to Figure 16, the DO bit is the MSB corresponding to Output 7 relative to the previous command word. The SO pin is not affected by the status of the Reset pin.

RST Pin

The 33298 reset ($\overline{\text{RST}}$) pin is active low. It is used to clear the SPI Shift register. In doing so, all output switches are set at OFF. The device situated in the same system with an MCU, the MCU retains the Reset pin of the device in a logic low state. Retention ensures all outputs to be OFF until both the V_{DD} and V_{PWR} pin voltages are adequate for predictable operation. Retention of the device Reset pin takes place only upon initial system power up. After the 33298 is reset, the MCU is ready to assert system control with all output switches initially OFF.

If the V_{PWR} pin of the 33298 experiences a low voltage, following normal operation, the MCU should pull the Reset pin low to shutdown the outputs and clear the input data register. The Reset pin is active low and has an internal pull-down incorporated, insuring operational predictability should the external pull-down of the MCU open circuit. The internal pull-down is only 25 μA , affording safe and easy interfacing to the MCU. The Reset pin of the 33298 should be pulled to a logic low state for a duration of at least 250 ns, ensuring reliable a reset.

A simple power ON reset delay of the system can be programmed through the use of an RC network comprised of a shunt capacitor from the Reset pin to Ground and a resistor to V_{DD} , illustrated in Figure 15. Care should be exercised ensuring proper discharge of the capacitor. Careful attention eliminates adverse delay of the Reset and damage of the MCU if it pulls the Reset line low, thereby accomplishing initialization for turn ON delay. It may be easier to incorporate delay into the software program and use a parallel port pin of the MCU to control the 33298 Reset pin.

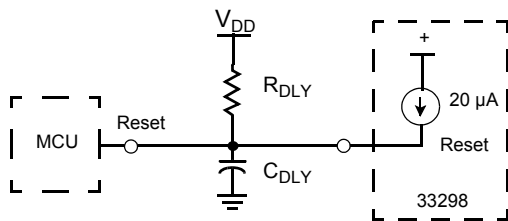

Figure 15. Power ON Reset

SFPD Pin

The Short Fault Protect Disable (SFPD) pin is used to prevent the outputs from latching-off due to an over current

condition. This feature provides control of incandescent lamp loads where in-rush currents exceed the device's analog current limits. Essentially the SFPD pin determines whether the 33298 output(s) will instantly shutdown upon sensing an output short or remain ON in a current limiting mode of operation until the output short is removed or thermal shutdown is reached. If the SFPD pin is tied to $V_{DD} = 5.0 \text{ V}$ the 33298 output(s) will remain ON in a current limited mode of operation upon encountering a load short to supply or over current condition. When the SFPD pin is grounded, a short circuit will immediately shut down only the output affected. Other outputs not having a fault condition will operate normally. The short circuit operation is addressed in more detail later.

Power Consumption

The 33298 has extremely low power consumption in both the operating and standby modes. In the standby, or *Sleep* mode, with $V_{DD} \leq 2.0 \text{ V}$, the current consumed by the V_{PWR} pin is less than 25 μA . In the operating mode, the current drawn by the V_{DD} pin is less than 4.0 mA (1.0 mA typical) while the current drawn at the V_{PWR} pin is 2.0 mA maximum (1.0 mA typical). During normal operation, turning outputs ON increases I_{PWR} by only 20 μA per output. Each output experiencing a *soft short* (over current conditions just under the current limit), adds 0.5 mA to the I_{PWR} current.

Paralleling of Outputs

Using MOSFETs as output switches permits connecting any combination of outputs together. $R_{DS(on)}$ of MOSFETs have an inherent positive temperature coefficient providing balanced current sharing between outputs without destructive operation (bipolar outputs could not be paralleled in this fashion as thermal run-away would likely occur). The device can even be operated with all outputs tied together. This mode of operation may be desirable in the event the application requires lower power dissipation, or the added capability of switching higher currents.

Performance of parallel operation results in a corresponding decrease in $R_{DS(on)}$ while the Output OFF Open Load Detect Currents and the Output Current Limits increase correspondingly (by a factor of eight if all outputs are paralleled). Less than 125 m Ω $R_{DS(on)}$ at 25°C with current limiting of eight to 24 A will result if all outputs are paralleled together. There will be no change in the over voltage detect or the OFF output threshold voltage range. The advantage of paralleling outputs within the same 33298 affords the existence of minimal $R_{DS(on)}$ and output clamp voltage variation between outputs.

Typically, the variation of $R_{DS(on)}$ between outputs of the same device is less than 0.5 percent. The variation in clamp voltages, potentially affecting dynamic current sharing, is less than five percent. Paralleling outputs from two or more different devices is possible, but it is not recommended. There is no guarantee the $R_{DS(on)}$ and clamp voltage of the two devices will match. System level thermal design analysis and verification should be conducted whenever paralleling outputs; particularly where different devices are involved.

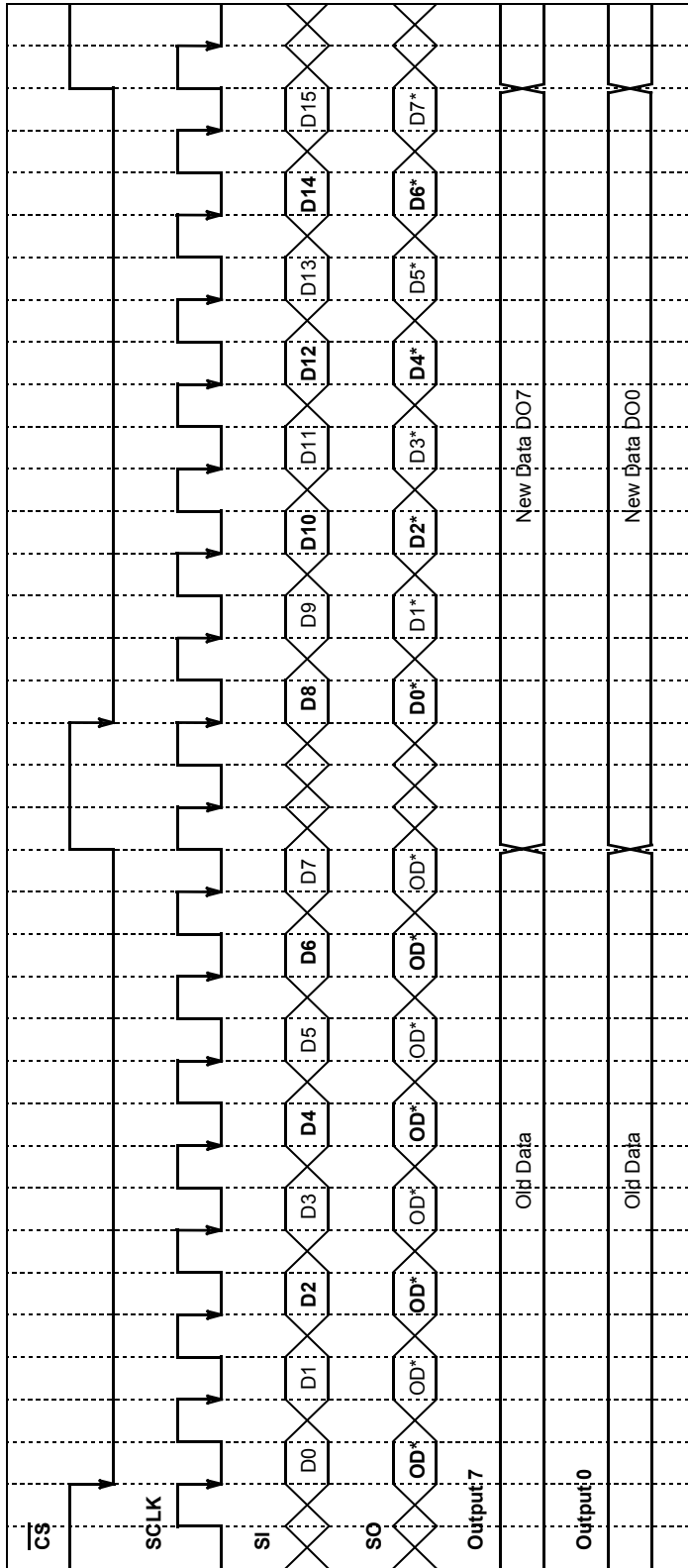

NOTES: 1. Reset pin is in a logic high-state during the above operation.
 2. D0, D1, D2, ..., and D15 relate to the ordered entry of program data into the MC33298 with D0/D8 bits (MSB) corresponding to Output 7 and D7/D15 corresponding to Output 0.
 3. OD*, D1*, D2*, ..., and D7* relate to the ordered data out of the 33298 with D0* bit (MSB) corresponding to Output 7.
 4. OD* corresponds to Old Databits.
 5. For brevity, only D07 and D00 are shown which respectively correspond to Output 7 and Output 0.

Data Transfer Timing (General)

CS High-to-Low	SO pin is enabled. Output Status information transferred to Output Shift Register.
CS Low-to-High	Data from the Shift Register is transferred to the Output Power Switches.
SO	Will change state on the rising edge of the SCLK pin signal.
SI	Will accept data on the falling edge of the SCLK pin signal.

Figure 16. Data Transfer Timing

FAULT LOGIC OPERATION

Introduction

The MCU can perform a parity check of the fault logic operation by comparing the command 8-bit word to the status 8-bit word. Assume after system reset, the MCU first sends an 8-bit command word to the 33298. This word is called Command Word 1. Each output to be turned ON will have its corresponding data bit low. Refer to the data transfer timing illustration in Figure 16.

As Command Word 1 is being written into the Shift register of the 33298, a status word is being simultaneously written and received by the MCU. However, the word being received by the MCU is the status of the previous write word to the 33298, Status Word 0. If the command word of the MCU is written a second time (Command Word 2 = Command Word 1), the word received by the MCU, Status Word 2, is the status of Command Word 1. The timing diagram illustrated in Figure 16 depicts this operation. Status Word 2 is then compared with Command Word 1. The MCU will Exclusive OR Status Word 2 with Command Word 1 to determine if the two words are identical. If the two words are identical, faults do not exist. The timing between the two write words must be greater than 100 μ s to receive proper drain status. The system data bus integrity may be tested by writing two like words to the 33298 within a few microseconds of each other.

Initial System Setup Timing

The MCU can monitor two kinds of faults:

1. Communication errors on the data bus
2. Actual faults of the output loads

After initial system start up or reset, the MCU will write one word to the 33298. If the word is repeated within approximately five microseconds of the first word, the word received by the MCU, at the end of the repeated word, serves as a confirmation of data bus integrity (1). At start up, the 33298 will take 25 to 100 μ s before a repeat of the first word should be repeated at least 100 μ s later to verify the status of the outputs.

The SO of the 33298 will indicate any one of four faults. The four possible faults are:

1. Over Temperature
2. Output OFF Open Fault
3. Short Fault (over current)
4. V_{PWR} Over Voltage Fault.

All of these faults, with the exception of the Over Voltage Fault, are output specific. Over Temperature Detect, Output OFF Open Fault, and Output Short Detect are dedicated to each output separately such that the outputs are independent in operation. A V_{PWR} Over Voltage Detect is a *global* nature causing all outputs to be turned OFF.

Over Temperature Fault

Patent pending Over Temperature Detect and shutdown circuits are specifically incorporated for each individual output.

The shutdown following an Over Temperature condition is independent of the system clock and other logic signal. Each independent output shuts down at 155°C to 185°C. When an output shuts down due to an Over Temperature Fault, no other outputs are affected. The MCU recognizes the fault since the output was commanded to be ON and the status word indicates it is OFF. A maximum hysteresis of 20°C ensures an adequate time delay between output turn OFF and recovery. This avoids a very rapid turn ON and turn OFF of the device around the Over Temperature threshold. When the temperature falls below the recovery level for the Over Temperature Fault, the device will turn on only if the Command Word during the next write cycle indicates the output should be turned ON.

Over Voltage Fault

An Over Voltage condition on the V_{PWR} pin causes the 33298 to shut down all outputs until the over voltage condition is removed and the device is re-programmed by the SPI. The over voltage threshold on the V_{PWR} pin is specified as 28 V to 36 V with 1.0 V typical hysteresis. Following the over voltage condition, the next write cycle sends the SO pin the hexadecimal word \$FF (all ones) indicating all outputs are turned *off*. In this way, potentially dangerous timing problems are avoided and the MCU reset routine ensures an orderly startup of the loads. The 33298 does not detect an over voltage on the V_{DD} pin. Other external circuitry, such as the Motorola 33161 Universal Voltage Monitor, is necessary to accomplish this function.

Output OFF Open Load Fault

An Output OFF Open Load Fault is the detection and reporting of an *open* load when the corresponding output is disabled (input in a logic high state). To understand the operation of the Open Load Fault detect circuit; see Figure 17. The Output OFF Open Load Fault is detected by comparing the drain voltage of the specific MOSFET output to an internally generated reference. Each output has one dedicated comparator for this purpose.

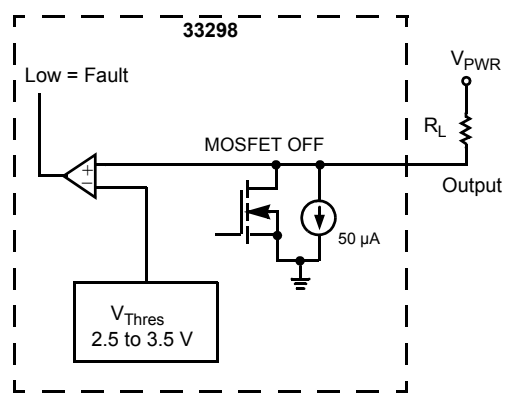

Figure 17. Output OFF Open Load Fault

An Output OFF Open Load Fault is indicated when the output voltage is less than the Output Threshold Voltage (V_{Thres}) of 0.6 to $0.8 \times V_{DD}$. Since the 33298 outputs function as switches, during normal operation, each MOSFET output should either be completely turned ON or OFF. By design, the threshold voltage was selected to be between the ON and OFF voltage of the MOSFET. During normal operation, the ON state V_{DS} voltage of the MOSFET is less than the threshold voltage and the OFF state V_{DS} voltage is greater than the threshold voltage. This design approach provides using the same threshold comparator for Output Open Load Detect in the OFF state and Short Circuit Detect in the ON state. See Figure 18 for an understanding of the Short Circuit Detect circuit. With $V_{DD} = 5.0 \text{ V}$, an OFF state output voltage of less than 3.0 V will be detected as an Output OFF Open Load Fault while voltages greater than 4.0 V will not be detected as a fault.

The 33298 has an internal pull-down current source of $50 \mu\text{A}$, illustrated in Figure 17 between the MOSFET drain and ground. This current source prevents the output from floating up to V_{PWR} if there is an open load or internal wire bond failure. The internal comparator compares the drain voltage with a reference voltage, V_{Thres} (0.6 to $0.8 \times V_{DD}$). If the output voltage is less than this reference voltage, the 33298 will declare the condition to be an open load fault.

During steady-state operation, the minimum load resistance (R_L) required to prevent false fault reporting during normal operation can be located using the following equation:

Therefore, the load resistance necessary to prevent false open load fault reporting is (using Ohm's Law) equal to $92 \text{ k}\Omega$ or less.

During output switching, especially with capacitive loads, a false output OFF Open Load Fault may be triggered. To prevent this false fault from being reported an internal fault filter in the range of 25 to $100 \mu\text{s}$ is incorporated. The duration in which a false fault may be reported is a function of the load impedance (R_L, C_L, L_L), $R_{DS(on)}$, and C_{OUT} of the MOSFET as well as the supply voltage (V_{PWR}). The rising edge of \overline{CS} triggers a built-in fault delay timer which must time-out (25 or $100 \mu\text{s}$) before the fault comparator is enabled to detect at faulted threshold. The circuit automatically returns to normal operation once the condition causing the Open Load Fault is removed.

Shorted Load Fault

A short load, or over current fault can be caused by any output being shorted directly to supply, or an output experiencing a current greater than the current limit.

There are three safety circuits progressively in operation during load short conditions providing system protection. They are:

1. The output current of the device is monitored in an analog fashion using a SENSEFET™ approach and current limited.
2. The output current of the device is sensed by monitoring the MOSFET drain voltage.

3. The output thermal limit of the device is sensed, and when attained, causes only the specific faulted output to be latched OFF, allowing all remaining outputs to operate normally.

Each of the three protection mechanisms are incorporated in their output providing robust independent output operation.

The analog current limit circuit is always active, monitoring the output drain current. An over current condition causes the gate control circuitry to reduce the gate-to-source voltage imposed on the output MOSFET, re-establishing the load current in compliance with current limit (1.0 to 3.0 A) range. Time required for the current limit circuitry to act is less than $20 \mu\text{s}$. Therefore, currents higher than 1.0 to 3.0 A will never be seen for more than $20 \mu\text{s}$ (a typical duration is $10 \mu\text{s}$). If the current of an output attempts to exceed the predetermined limit of 1.0 to 3.0 A (2.0 A nominal), the V_{DS} voltage will exceed the V_{Thres} voltage and the over current comparator will be tripped, illustrated in Figure 18.

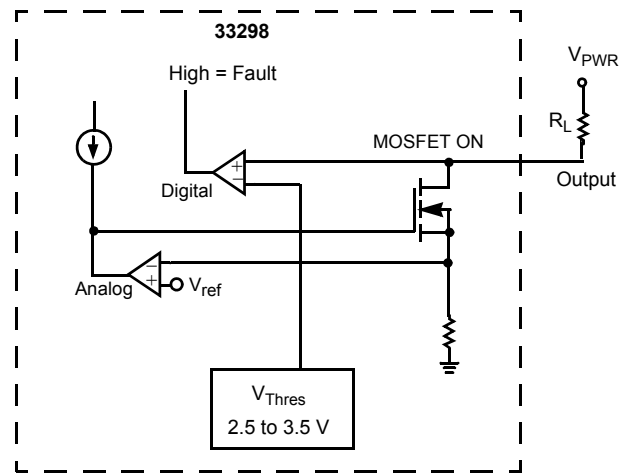

Figure 18. Short Circuit Detect and Analog Current Limiting Circuit

The status of SFPD determines whether the 33298 will shut down immediately, or continue to operate in an analog current limited mode until either the short circuit (over current) condition is removed or thermal shutdown is reached.

Grounding the SFPD pin enables the short fault protection shutdown circuitry. Consider a load short (output short to supply) occurring on an output before, during, and after output turn ON. When the \overline{CS} signal rises to the high logic state, the corresponding output is turned ON, activating a delay timer. The duration of the delay timer is 70 to $250 \mu\text{s}$. If the short circuit takes place before the output is turned ON, the delay experienced is the entire 70 μs to $250 \mu\text{s}$ followed by shutdown. If the short occurs during the delay time, the shutdown still occurs after the delay time has elapsed. However, if the short circuit occurs after the delay time, shutdown is immediate (within $20 \mu\text{s}$ after sensing). The purpose of the delay timer is to

prevent *false* faults from being reported when switching capacitive loads.

If the SFPD pin is at 5.0 V, or V_{DD} , an output will not be disabled when an over current is detected. The specific output will, within 5.0 to 10 μ s of encountering the short circuit, go into an analog current limited mode. This feature is especially useful when switching incandescent lamp loads, where high in-rush currents experienced during startup last for 10 to 20 milliseconds.

Each output of the 33298 has its own over current shutdown circuitry. Over temperature, and the over voltage faults are not affected by the SFPD pin's state.

Both load current sensing and output voltage sensing are incorporated for Short Fault detection with actual detection occurring slightly *after* the onset of current limit. The current limit circuitry incorporates a SENSEFET™ approach to measure the total drain current. This calls for the current through a small number of cells in the power MOSFET to be measured and the result multiplied by a constant, giving the total current. Wherein output shutdown circuitry measures the drain-to-source voltage, shutting down the output if its threshold (V_{Thres}) is exceeded.

Short fault detection is accomplished by sensing the output voltage and comparing it to V_{Thres} . The lowest V_{Thres} requires a voltage of 2.5 V to be sensed. For an enabled output, with $V_{DD} = 5.0 \pm 0.5$ V, an output voltage in excess of 3.5 V *will* be detected as a *short*, or over current condition, while voltages less than 2.5 V will *not* be detected as *shorts*.

Over Current Recovery

If the SFPD pin is in a high logic state, the circuit returns to normal operation automatically after the short circuit is removed (unless thermal shutdown has occurred).

If the SFPD pin is grounded and over current shutdown occurs, removing the short circuit will result in the output remaining OFF until the next write cycle. If the short circuit is *not* removed, the output will turn ON for the delay time (70 to 250 μ s) and then turn OFF for every write cycle commanding a turn ON.

SFPD Pin Voltage Selection

Since the voltage condition of the SFPD pin controls the activation of the short fault protection (i.e., shutdown) mode equally for all eight outputs, the load having the longest duration of in-rush current determines what voltage (state) the SFPD pin should be. Usually if at least one load is, an incandescent lamp for example, the in-rush current on that input will be milliseconds in duration. Therefore, setting SFPD at 5.0 V will prevent shutdown of the output due to the in-rush current. The system relies only on the over temperature shutdown to protect the outputs and the loads. The 33298 was designed to switch GE194 incandescent lamps, or equivalents, with the SFPD pin

in a grounded state. Considerably larger lamps can be switched with the SFPD pin held in a high logic state.

Sometimes both a delay period greater than 70 to 250 μ s (current limiting of the output) followed by an immediate over current shutdown is necessary. This can be accomplished by programming the SFPD pin to 5.0 V for the extended delay period, allowing the outputs to remain ON in a current limited mode, then grounding it to accomplish the immediate shutdown after a period of time. Additional external circuitry is required to implement this type of function. An MCU parallel output port can be devoted to controlling the SFPD voltage during and after the delay period, is often a much better method. In either case, care should be taken to execute the SFPD start-up routine every time start-up or reset occurs.

Under Voltage Shutdown

An under voltage V_{DD} condition will result in the global shutdown of all outputs. The under voltage threshold is between 2.5 V and 3.5 V. When V_{DD} goes below the threshold, all outputs are turned OFF, thereby resetting the Serial Output Data register to indicate the same.

An under voltage condition at the V_{PWR} pin will *not* cause output shutdown and reset. When V_{PWR} is between 5.5 V and 9.0 V, the outputs will operate per the command word. However, the status as reported by the SO pin may not be accurate below 9.0 V V_{PWR} . Proper operation at V_{PWR} voltages below 5.5 V are not guaranteed.

Deciphering Fault Type

The 33298 SO pin can be used to determine what kind of system fault has occurred. With eight outputs having open load, over current, over temperature, and over voltage faults; a total of 25 different faults are possible. The SO status word received by the MCU will be compared with the word sent to the 33298 during the previous write cycle. For a specific output, if the SO bit compares with the corresponding SI bit of the previous word; the output is operating normal with no fault. Only when the SO bit and previous word SI bit differ is there a fault indicated. If the two words are *not* the same, the MCU should be programmed to determine which output or outputs are faulted.

If, for a specific output, the initial SI command bit were logic high, the output would be programmed to be OFF; if, upon the next command word being entered, a logic low came back on SO, for that specific output's corresponding bit, an Output-OFF Open-Load fault would be indicated. The resulting SO bit, for that specific output, would be different from that entered during the previous word for that SI bit, indicating the fault. The eight output-off open-load faults are therefore most easily detected.

If for a specific output, the initial SI command bit were a logic low, calling for the output to be programmed *on*; upon the next word command being entered, the corresponding bit came back with a logic high on SO, an output over current fault would be indicated. An over current fault is always reported by the SO output and is independent of the logic state existing on the

SFPD pin. When the SFPD pin is in a logic high state, an over current condition will be reported on the SO pin. However, limiting output current is in effect and the output is permitted to operate if the over current condition does not drive output into an over temperature fault. An over temperature fault will shutdown the specific output effected for the duration of the over temperature condition.

Over current and over temperature faults are often related. Turning the effected output switches OFF and waiting for some time to allow the output to cool down should make these types of faults go away. *Soft* over current faults can sometimes be determined over hard short faults and over temperature faults by observing the time required for the device to recover. However, in general over current and over temperature faults can not be differentiated in normal application usage.

An advantage of the synchronous serial output is multiple faults can be detected with only one (SO) pin being used for fault status reporting.

If V_{PWR} experiences an over voltage condition, all outputs will immediately be turned OFF and remain latched off. A new command word is required to turn the outputs back on following an over voltage condition.

Output Voltage Clamping

Each output of the 33298 incorporates an internal voltage clamp to provide fast turn-off and transient protection of the output. Each clamp independently limits the drain to source voltage to 53 V at drain currents of 0.5 A and keeps the output

transistors from avalanching by causing the transient energy to be dissipated in the linear mode. See Figure 19. The total energy clamped (E_J) can be calculated by multiplying the current area under the current curve (I_A) times the clamp voltage (V_{CL}) times the duration the clamp is active (t).

Characterization of the output clamps, using a single pulse non-repetitive method at 0.5 A, indicate the maximum energy to be 50 mJ at 150°C junction temperature per output.

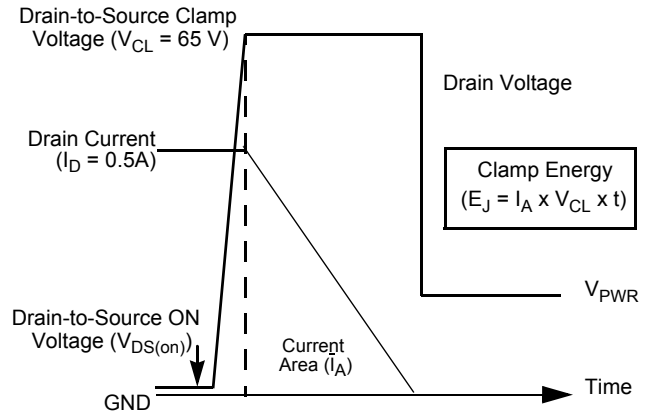

Figure 19. Output Voltage Clamping

THERMAL CHARACTERIZATION

Thermal Model

Logic functions take up a very small area of the die and generate negligible power. In contrast, the output transistors take up most of the die area and are the primary contributors of power generation. The thermal model illustrated in Figure 20 was developed for the 33298 mounted on a typical PC board. The model is accurate for both steady state and transient thermal conditions. The components R_{D0} through R_{D7} represent the steady state thermal resistance of the silicon die for transistor outputs 0 through 7, while C_{D0} through C_{D7} represent the corresponding thermal capacitance of the silicone die translator outputs and plastic. The device area and die thickness determine the values of these specific components.

The thermal impedance of the package from the internal mounting flag to the outside environment is represented by the terms R_{pkg} and C_{pkg} . The steady state thermal resistance of leads and the PC board make up the steady state package thermal resistance, R_{pkg} . The thermal capacitance of the package is made up of the combined capacitance of the flag and the PC board. The mode compound was not modeled as a specific component but it is factored into the other overall component values.

The battery voltage in the thermal model represents the ambient temperature the device and PC board are subjected

to. The I_{PWR} current source represents the total power dissipation and is calculated by totalling the power dissipation of each individual output transistor. This is easily accomplished by knowing $R_{DS(on)}$ and load current of the individual outputs.

Very satisfactory steady state and transient results are experienced with this thermal model. Tests indicate the model accuracy to have less than 10 percent error. Output interaction with an adjacent output is believed to be the main contributor to the thermal inaccuracy. Tests indicate little or no detectable thermal affects caused by distant output transistors isolated by one or more other outputs. Tests were conducted with the device mounted on a typical PC board placed horizontally in a 33 cubic inch still air enclosure. The PC board was made of FR4 material measuring 2.5 by 2.5 inches, having double sided circuit traces of 1.0 ounce copper soldered to each device pin. The board temperature was measured with thermal couple soldered to the board surface one inch away from the center of the device. The ambient temperature of the enclosure was measured with a second thermal couple located over the center of one inch distance from device.

Thermal Performance

Figure 20 illustrates the worst case thermal component parameters values for the 33298 in the 20-pin plastic power DIP and the SOP-24 wide body surface mount package. Pins 5, 6,

15, and 16 of the power DIP package are connected directly to the lead frame flag. The parameter values indicated take into account adjacent output combinations. The characterization was conducted over power dissipation levels of 0.7 to 17 W. The junction-to-ambient temperature thermal resistance was found to be 37°C/W with a single output active (31°C/W with all outputs dissipating equal power) and in conjunction with this, the thermal resistance from junction to PC board ($R_{\text{junction-board}}$) was found to be 27°C/W (board temperature, measure one inch from device center). Additionally, the thermal resistance from junction-to-heatsink lead was found to approximate 10°C/W. Devoting additional PC board metal around the heatsinking pins improved R_{pkg} from 30° to 28° C/W.

The SOP-24 package has pins 5, 6, 7, 8, 17, 18, 19, and 20 of the package connected directly to the lead frame flag. Characterization was conducted in the same manner as with the DIP package. The junction-to-ambient temperature resistance was found to be 40°C/W with a single output active (34°C/W with all outputs dissipating equal power) and the

thermal resistance from junction-to-PC board ($R_{\text{junction-board}}$) to be 30°C/W (board temperature, measure one inch from device center). The junction-to-heatsink lead resistance was found again to approximate 10°C/W. Devoting additional PC board metal around the heatsinking pins for this package improved the R_{pkg} from 33° to 31° C/W.

The total power dissipation available is dependent on the number of outputs enabled at any one time. At 25°C the $R_{\text{DS(on)}}$ in 450 mΩ with a coefficient of 6500 ppm/°C. For the junction temperature to remain below 150°C, the maximum available power dissipation must decrease as the ambient temperature increases. Figures 21 and 22 depict the per output limit of current at ambient temperatures necessary when one, four, or eight outputs are enable ON. Figure 23 illustrates how the $R_{\text{DS(on)}}$ output value is affected by junction temperature.

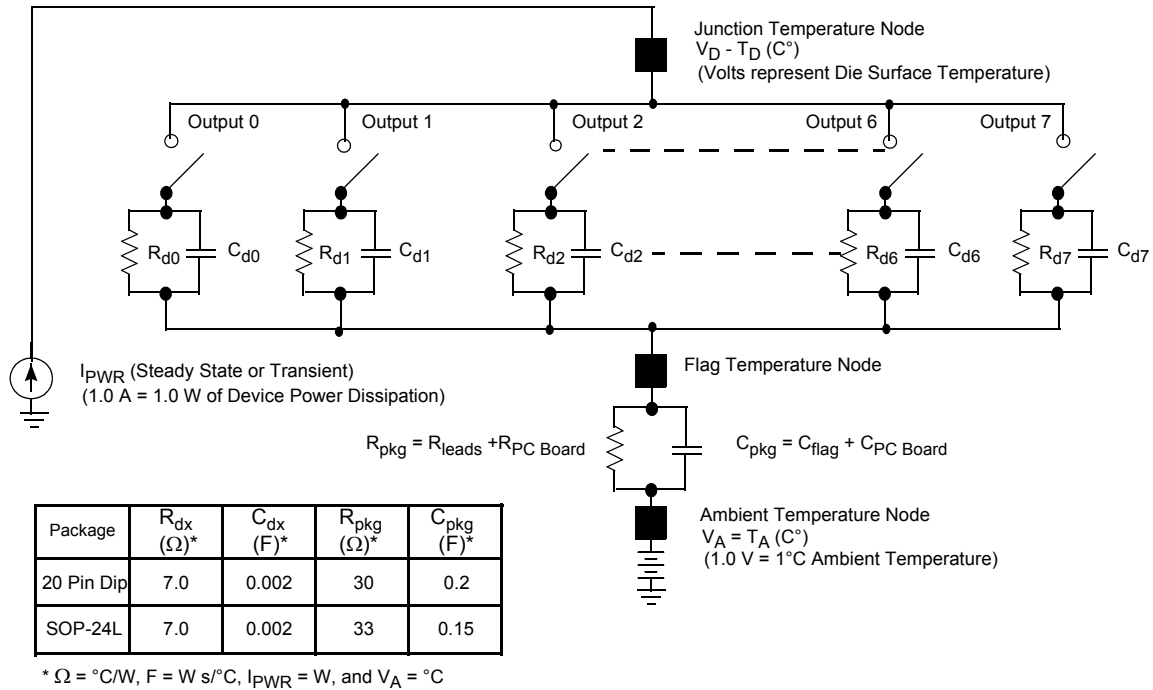

Figure 20. Thermal Model (Electrical Equivalent)

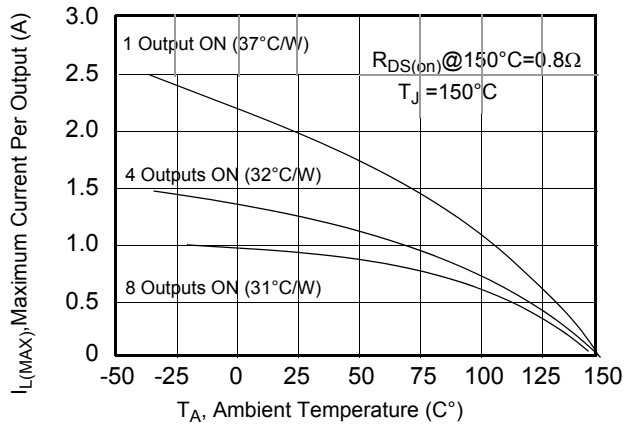

Figure 21. Maximum DIP Package Steady State Output Current vs. Ambient Temperature

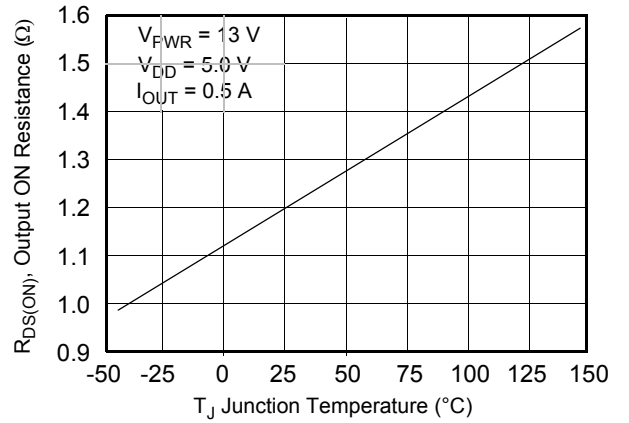

Figure 23. Maximum Output ON Resistance vs. Junction Temperature

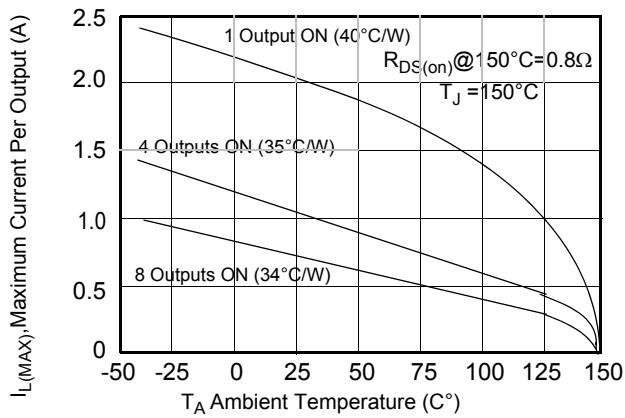
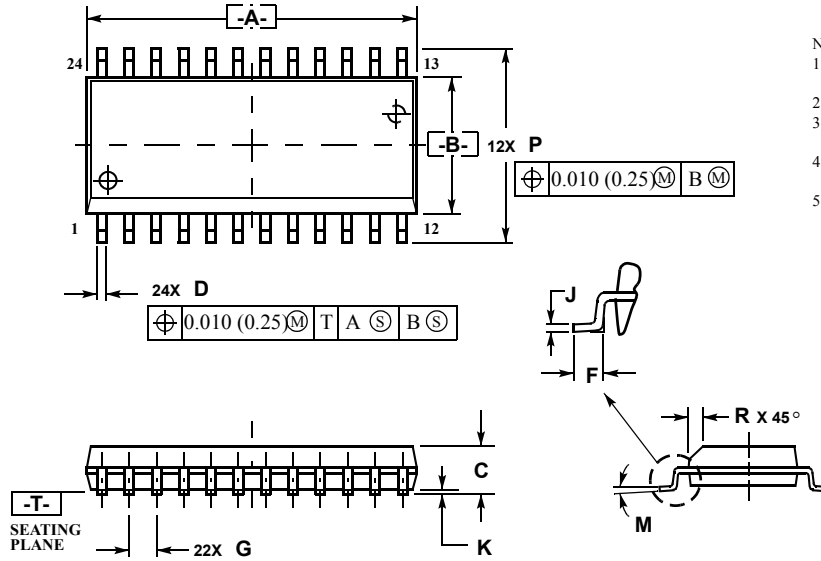

Figure 22. Maximum SOP Package Steady State Output Current vs. Ambient Temperature

PACKAGE DIMENSIONS

**DW SUFFIX
PLASTIC PACKAGE
CASE 751E-04
SOP (16+4+4)L**



NOTES:

1. DIMENSIONING AND TOLERANCING PER ANSI Y14.5M, 1982.
2. CONTROLLING DIMENSION: MILLIMETER.
3. DIMENSIONS A AND B DO NOT INCLUDE MOLD PROTRUSION.
4. MAXIMUM MOLD PROTRUSION 0.15 (0.006) PER SIDE.
5. DIMENSION D DOES NOT INCLUDE DAMBAR PROTRUSION. ALLOWABLE DAMBAR PROTRUSION SHALL BE 0.13

DIM	MILLIMETERS		INCHES	
	MIN	MAX	MIN	MAX
A	15.25	15.54	0.601	0.612
B	7.40	7.60	0.292	0.299
C	2.35	2.65	0.093	0.104
D	0.35	0.49	0.014	0.019
F	0.41	0.90	0.016	0.035
G	1.27 BSC		0.050 BSC	
J	0.23	0.32	0.009	0.013
K	0.13	0.29	0.005	0.011
M	0°	8°	0°	8°
P	10.05	10.55	0.395	0.415
R	0.25	0.75	0.010	0.029

NOTES

NOTES

NOTES

Motorola reserves the right to make changes without further notice to any products herein. Motorola makes no warranty, representation or guarantee regarding the suitability of its products for any particular purpose, nor does Motorola assume any liability arising out of the application or use of any product or circuit, and specifically disclaims any and all liability, including without limitation consequential or incidental damages. "Typical" parameters can and do vary in different applications and actual performance may vary over time. All operating parameters, including "Typicals", must be validated for each customer application by customer's technical experts. Motorola does not convey any license under its patent rights nor the rights of others. Motorola products are not designed, intended, or authorized for use as components in systems intended for surgical implant into the body, or other applications intended to support or sustain life, or for any other application in which the failure of the Motorola product could create a situation where personal injury or death may occur. Should Buyer purchase or use Motorola products for any such unintended or unauthorized application, Buyer shall indemnify and hold Motorola and its officers, employees, subsidiaries, affiliates, and distributors harmless against all claims, costs, damages, and expenses, and reasonable attorney fees arising out of, directly or indirectly, any claim of personal injury or death associated with such unintended or unauthorized use, even if such claim alleges that Motorola was negligent regarding the design or manufacture of the part. Motorola and are registered trademarks of Motorola, Inc. Motorola, Inc. is an Equal Opportunity/Affirmative Action Employer.

MOTOROLA and the Stylized M Logo are registered in the US Patent and Trademark Office. All other product or service names are the property of their respective owners.

© Motorola, Inc. 2002

HOW TO REACH US:

USA/EUROPE/LOCATIONS NOT LISTED: Motorola Literature Distribution: P.O. Box 5405, Denver, Colorado 80217.

1-303-675-2140 or 1-800-441-2447

JAPAN: Motorola Japan Ltd.; SPS, Technical Information Center, 3-20-1 Minami-Azabu. Minato-ku, Tokyo 106-8573 Japan.

81-3-3440-3569

ASIA/PACIFIC: Motorola Semiconductors H.K. Ltd.; Silicon Harbour Centre, 2 Dai King Street, Tai Po Industrial Estate, Tao Po, N.T.,

Hong Kong. 852-26668334

TECHNICAL INFORMATION CENTER: 1-800-521-6274



MOTOROLA

SUNSTAR 商斯达实业集团是集研发、生产、工程、销售、代理经销、技术咨询、信息服务等为一体的高科技企业，是专业高科技电子产品生产厂家，是具有 10 多年历史的专业电子元器件供应商，是中国最早和最大的仓储式连锁规模经营大型综合电子零部件代理分销商之一，是一家专业代理和分销世界各大品牌 IC 芯片和电子元器件的连锁经营综合性国际公司，专业经营进口、国产名厂名牌电子元件，型号、种类齐全。在香港、北京、深圳、上海、西安、成都等全国主要电子市场设有直属分公司和产品展示展销窗口门市部专卖店及代理分销商，已在全国范围内建成强大统一的供货和代理分销网络。我们专业代理经销、开发生产电子元器件、集成电路、传感器、微波光电元器件、工控机/DOC/DOM 电子盘、专用电路、单片机开发、MCU/DSP/ARM/FPGA 软件硬件、二极管、三极管、模块等，是您可靠的一站式现货配套供应商、方案提供商、部件功能模块开发配套商。商斯达实业公司拥有庞大的资料库，有数位毕业于著名高校——有中国电子工业摇篮之称的西安电子科技大学（西军电）并长期从事国防尖端科技研究的高级工程师为您精挑细选、量身订做各种高科技电子元器件，并解决各种技术问题。

更多产品请看本公司产品专用销售网站：

商斯达中国传感器科技信息网：<http://www.sensor-ic.com/>

商斯达工控安防网：<http://www.pc-ps.net/>

商斯达电子元器件网：<http://www.sunstare.com/>

商斯达微波光电产品网：[HTTP://www.rfoe.net/](http://www.rfoe.net/)

商斯达消费电子产品网：<http://www.icasic.com/>

商斯达实业科技产品网：<http://www.sunstars.cn/>

传感器销售热线：

地址：深圳市福田区福华路福庆街鸿图大厦 1602 室

电话：0755-83370250 83376489 83376549 83607652 83370251 82500323

传真：0755-83376182 (0) 13902971329 MSN: SUNS8888@hotmail.com

邮编：518033 E-mail:szss20@163.com QQ: 195847376

深圳赛格展销部：深圳华强北路赛格电子市场 2583 号 电话：0755-83665529 25059422

技术支持：0755-83394033 13501568376

欢迎索取免费详细资料、设计指南和光盘；产品凡多，未能尽录，欢迎来电查询。

北京分公司：北京海淀区知春路 132 号中发电子大厦 3097 号

TEL: 010-81159046 82615020 13501189838 FAX: 010-62543996

上海分公司：上海市北京东路 668 号上海赛格电子市场 2B35 号

TEL: 021-28311762 56703037 13701955389 FAX: 021-56703037

西安分公司：西安高新开发区 20 所(中国电子科技集团导航技术研究所)

西安劳动南路 88 号电子商城二楼 D23 号

TEL: 029-81022619 13072977981 FAX:029-88789382